

VibroGo®

VibroGo® is the truly portable, battery powered laser vibrometer for field studies and quick and easy condition monitoring of machines and facilities. It comprises sensor, data acquisition and viewer.

VibroGo® measures vibrations on the go and without contact, covering a wide frequency range of up to 320 kHz. Use VibroGo® for a better understanding of dynamics, acoustics and even ultrasonics in nature and technology – for research, product development and quality assurance. With auto and remote focus you can easily set up the laser beam on your test object and set the measurement range via touch screen. Directly retrieve the vibrational velocity, displacement and acceleration.

VibroGo® can store hours of data and displays the measurement signal in time and frequency domain directly on the touch screen or on other devices via a web browser for monitoring. The integrated signal level indicator secures the optimum operation. Select high pass and frequency bandwidth filters for clean signals. Thanks to the ASE Adaptive Signal Enhancement VibroGo® measures reliably on any surface.

Use the VibroLink Ethernet or WLAN interface for a fully digital transfer of measurement data to a computer with the VibSoft data acquisition and analysis software. Alternatively, connect any data acquisition to the analog BNC output and control VibroGo® remotely via WLAN and web browser.



Highlights

- Study acoustics and dynamics with laser precision in field and lab
- On-board storage, monitoring and quick analysis of measurement data
- Wireless measurement and remote control from everywhere
- Lightweight, versatile and outdoor-proof (IP64)
- Measure from a safe distance up to 30 m, from DC up to 320 kHz
- Velocity range up to ± 6 m/s
- Optional mobile power supply for up to 3 hours operation

VibroGo®

Truly portable laser vibration measurement
Datasheet

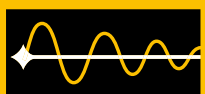

Technical data



Metrological specifications

Model	VibroGo® VGO-200					
Package	Max. frequency	Velocity output	Max. velocity full scale	Displacement output ²	Acceleration output ²	Upgradeable later ³
Lab	25 kHz	7 ranges	±1 m/s	16 ranges	11 ranges	yes
Explorer	25 kHz	8 ranges	±2 m/s	16 ranges	12 ranges	yes
Sonic	100 kHz	8 ranges	±2 m/s	16 ranges	14 ranges	yes
Pioneer ¹	320 kHz	13 ranges	±6 m/s	19 ranges	17 ranges	yes

¹ VibroGo® Pioneer is a special model VGO-200-P. Therefore, no upgrades from VibroGo® Lab, Explorer or Sonic to VibroGo® Pioneer are possible.

² optional

³ Features like displacement or acceleration output, data recorder/viewer or wireless connectivity can be upgraded at any time later. For VibroGo® Lab and Explorer max. frequency and max. velocity can also be upgraded up to 100 kHz and ± 2 m/s, an upgrade to VibroGo® Pioneer (320 kHz and ± 6 m/s) is not possible.

Measurement range velocity (peak)	Resolution ¹ for selected frequency ² [µm/s/√Hz]					Model/package			
	@ 5 kHz	@ 12.5 kHz	@ 50 kHz	@ 100 kHz	@ 320 kHz	Lab	Explorer	Sonic	Pioneer
5	< 0.01	< 0.02	< 0.03	< 0.05	< 0.2				•
10	< 0.01	< 0.02	< 0.03	< 0.05	< 0.2	•	•	•	•
20	< 0.01	< 0.02	< 0.03	< 0.05	< 0.2	•	•	•	•
50	< 0.02	< 0.02	< 0.03	< 0.05	< 0.2	•	•	•	•
100	< 0.02	< 0.02	< 0.03	< 0.05	< 0.2	•	•	•	•
200	< 0.04	< 0.04	< 0.04	< 0.06	< 0.2	•	•	•	•
500	< 0.1	< 0.1	< 0.1	< 0.1	< 0.2	•	•	•	•
1,000	< 0.2	< 0.2	< 0.2	< 0.2	< 0.2	•	•	•	•
2,000	< 0.4	< 0.4	< 0.4	< 0.4	< 0.4		•	•	•
3,000	< 0.4	< 0.4	< 0.4	< 0.4	< 0.4				•
4,000	< 0.5	< 0.5	< 0.5	< 0.5	< 0.5				•
5,000	< 0.6	< 0.6	< 0.6	< 0.6	< 0.8				•
6,000	< 0.8	< 0.8	< 0.8	< 0.8	< 0.8				•

¹ The noise-limited resolution is defined as the signal amplitude (rms) at which the signal-to-noise ratio is 0 dB with 1 Hz spectral resolution, measured on 3M Scotchlite™ Tape (reflective film).

For digital data transfer via the VibroLink Ethernet interface, a digital resolution of 168 nm/s for VibroGo® Pioneer and 336 nm/s for VibroGo® Lab, Explorer or Sonic can be reached in the smallest measurement range. The digital resolution is defined by the quantization step of the measured data, which are transferred with a bit depth of 16-bit.

² Some of the listed frequencies are available only in some of the VibroGo® models or packages (maximum frequency bandwidth 25 kHz for VibroGo® Lab and Explorer and 100 kHz for VibroGo® Sonic).



Measurement range displacement (peak) ¹	Resolution ²	Model/Package		Measurement range acceleration (peak) ³	Model/Package			
mm	pm	Lab, Explorer, Sonic	Pioneer	m/s ²	Lab	Explorer	Sonic	Pioneer
0.0002	6.78		•	2				•
0.0005	16.95	•	•	5	•	•	•	•
0.001	33.91	•	•	10	•	•	•	•
0.002	67.82	•	•	20	•	•	•	•
0.005	169.5	•	•	50	•	•	•	•
0.01	339.1	•	•	100	•	•	•	•
0.02	678.2	•	•	200	•	•	•	•
0.05	1,695	•	•	500	•	•	•	•
0.1	3,390	•	•	1,000	•	•	•	•
0.2	6,781	•	•	2,000	•	•	•	•
0.5	16,954	•	•	5,000	•	•	•	•
1	33,908	•	•	10,000	•	•	•	•
2	67,816	•	•	20,000		•	•	•
5	169,542	•	•	50,000			•	•
10	339,084	•	•	100,000			•	•
20	678,168	•	•	200,000				•
50	1,695,421	•	•	500,000				•
100	3,390,842		•					
200	6,781,684		•					

¹ For digital and analog displacement output, the option VGO-DISPOUT is required.

² The resolution corresponds to the quantization step at the analog output. Noise limited resolution (frequency dependent): < 80 fm/√Hz for VibroGo® Sonic at 100 kHz and < 100 fm/√Hz for VibroGo® Pioneer at 320 kHz in the smallest measurement range. The noise-limited resolution is defined as the signal amplitude (rms) at a signal-to-noise ratio of 0 dB and a spectral resolution of 1 Hz.

³ For digital and analog acceleration output, the option VGO-ACCOUT is required.

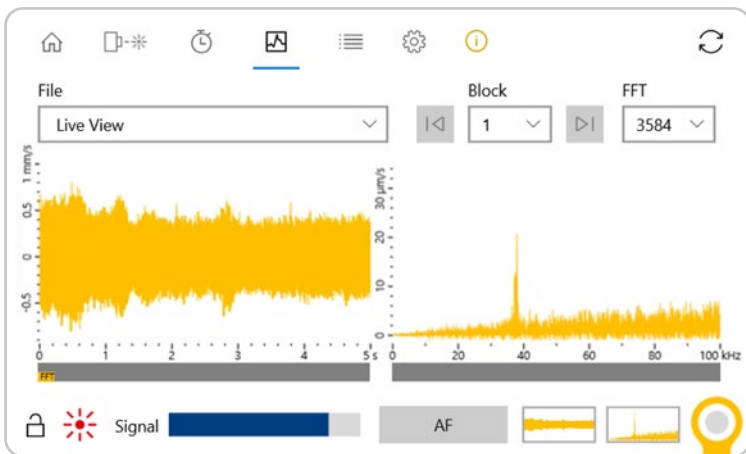

Monitor measured and recorded time signals and FFT spectra on the VibroGo® user interface with option VGO-DATAREC.



Decoder type	Digital velocity decoder, 7..13 ¹ measurement ranges Digital displacement decoder (optional), 16..19 ¹ measurement ranges Digital acceleration decoder (optional), 11..17 ¹ measurement ranges
Data recorder ²	Optional data recorder with integrated storage allows truly mobile operation by saving several hours ³ of measurement data directly on the VibroGo® without any additional data acquisition or computer device (requires option VGO-DATAREC)
Data viewer ²	The measured signal can be monitored during the measurement on the integrated touch screen or on connected devices in time and frequency domain. Saved measurements can also be loaded and viewed in time and frequency domain. (requires option VGO-DATAREC)
Data export ² for further analysis	The measured data can be imported easily and comfortably with VibSoft-VL (requires VibSoft 6.1 or newer). For analysis in 3rd party software, data can also be exported in different formats like ASCII, WAV and PVR to a connected device. (requires option VGO-DATAREC)
Analog signal outputs	±4 V, BNC connector output for vibration signal velocity, can be switched to displacement or acceleration (optional), SYNC output to synchronize with an external device
Digital signal outputs	VibroLink digital interface for measurement data and signal level and remote control, requires VibSoft 5.5 or newer software and a A-CBL-000x Ethernet cable or VGO-WIC wireless connectivity with a WLAN-stick; VibroLink interface also allows remote control via Ethernet or WLAN (optional) from any device via web browser
Frequency bandwidth	DC to 320 kHz ¹
Max. velocity	±6 m/s ¹
Filters	Adjustable frequency bandwidth: 1 kHz, 5 kHz, 10 kHz, 25 kHz, 50 kHz ⁴ , 100 kHz ⁴ , 320 kHz ⁵ Digital high pass filters 13 Hz/104 Hz for VibroGo® Lab, Explorer and Sonic and 11 Hz/173 Hz for VibroGo® Pioneer ASE Adaptive Signal Enhancement for signal optimization on uncooperative surfaces
Signal level	Bargraph on touch screen
Analog input signals	Trigger input for starting the autofocus or switching the laser beam on/off
Wireless connectivity	Option VGO-WIC allows establishing a wireless connection to VibroGo® for data transfer to a system with VibSoft 5.5 or newer and for remote control and configuration of the sensor via web browser from any WLAN-enabled device; Wireless access is securely prohibited if option VGO-WIC is not activated!
Connectors	Industrial grade M12 Ethernet connector for VibroLink digital interface (CON 3) BNC output for analog signal (CON 2) USB port for optional WLAN-Stick Trigger Input and SYNC output (CON 4) Connector for power supply 12 V (CON 1)

¹ Depending on model

² All specifications of the feature VGO-DATAREC which includes data recorder, viewer and export are preliminary.

³ For VibroGo® Pioneer the amount of saved hours of measurement data is about 1 hour.

⁴ Frequency bandwidths of 50 kHz and 100 kHz only available in Sonic Package and VibroGo® Pioneer.

⁵ Frequency bandwidth 320 kHz only available in VibroGo® Pioneer.

Optical specifications	
Laser type	Helium Neon (HeNe)
Laser class	Class 2, < 1 mW output power
Laser wavelength	633 nm, visible red laser beam
Focus	Autofocus, remote focus, manual focus – controlled via touch screen or remotely via VibroLink interface
Minimum stand-off distance ¹	355 mm
Maximum stand-off distance ¹	ca. 30 m, depending on surface properties of measurement object
Exit beam diameter (1/e ²)	typ. 12.2 mm
Visibility maxima ^{1,2}	$x = 463 \text{ mm} + n \cdot 138 \text{ mm}$, $n = 0, 1, 2, 3, \dots$

¹ For definition of stand-off distance see drawing on last page, dimension „x“.

² The optimal stand-off distances where the signal level is at its maximum are called visibility maxima. The visibility maxima recur every 138 mm corresponding to the laser cavity length.

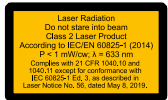

Working distance and laser spot size		
Stand-off distance	Laser spot size	Laser depth-of-field
[mm]	[µm]	[mm]
355	23	±0.6
463	30	±1.1
1,015	69	±5.9
1,992	138	±24
5,028	349	±152
9,996	699	±606
20,070	1,415	±2,485
30,006	2,139	±5,676

General specifications	
Interface/display	5" color touch screen with interactive menu guidance for setup, configuration and working with live or saved measurement data. Also allows remote control wireless (via WLAN) or via Ethernet
Weight	ca. 3.1 kg
Protection class	IP64 Resistance in salty environment verified according to DIN EN 60068-2-11 (closed or connected sockets and closed USB socket)
Dimensions [W x H x L]	see drawing on last page
Operating temperature	+5 °C ... +40 °C (41 °F ... 104 °F)
Storage temperature	-10 °C ... +65 °C (14 °F ... 149 °F)
Relative humidity	max. 80%, non-condensing
Power supply and power consumption	11 V ... 14.5 V DC, max. 25 W 12 V plug-in power supply included (100 V...240 VAC ±10%, 50/60 Hz, max. 50 VA), mobile power supply available as an option

Options and accessories



A-PPS-01
Plug-in power supply

Plug-in power supply 12 V AC / DC,
included in scope of delivery of VibroGo®



A-MPS-001
Mobile power supply

High-performance lightweight rechargeable battery (lithium polymer, A-MPS-PB1) for mobile power supply. Also includes battery charger with adapter plates for EU, UK, US and AU sockets, an A-MPS-C02 Power supply cable (length 2 m) and a convenient waterproof bag (A-MPS-BAG) that allows to attach the battery directly to the tripod



VibSoft: Data acquisition and analysis

VibSoft is a comprehensive and easy-to-use software package for digital or analog vibration data acquisition and analysis and remote control of VibroGo®. It closes the gap between raw signal acquisition and profound analysis of vibration measurement data even with special filters and signal enhancement dedicated to laser vibrometers. Further options like the powerful SignalProcessor (a Polytec math library for post-processing) and a scripting engine for individual post-processing and control make VibSoft an extremely powerful tool.

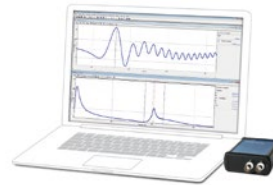
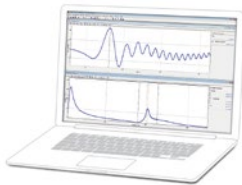

VibSoft-VL

The VibroLink interface allows for direct and fully digital data acquisition via Ethernet or WLAN. Thus, VibSoft-VL is the ideal lightweight solution for mobile use – set up quickly and easily, with reduced cabling and no need for additional data acquisition hardware. Furthermore, VibSoft-VL can comfortably import measured data saved on VibroGo® with the data recorder for later analysis.

VibSoft-20

USB based compact data acquisition system for measuring frequencies up to 20 kHz enabling the connection of one additional analog sensor. Suitable for laptop computers. Comprises VIB-E-220 Junction box.



Wireless connectivity ¹

A-WIC-00X WLAN stick
CE / FCC

WLAN stick for using wireless access.
Choose between CE-certified and FCC-certified.
Supports 802.11b/g/n WLAN standards with up to 150 Mbps data transfer speed when connected to an 802.11n device.



¹ For usage of WLAN sticks, the option VGO-WIC Wireless Connectivity is required. The wireless access is secured and not accessible if this option is not enabled.

Cables		
A-CBL-000X Ethernet cable RJ 45/M12 5 m / 10 m	Ethernet cable for digital data transfer between VibroGo® and computer (VibSoft 5.5 or newer required). Connector RJ45 on one side, M12 industrial connector on the other side. Standard length 5 m included, optional 10 m.	
VGO-C-200-C04 Trigger cable 1.5 m	For connection with the Trigger input (CON 4) (included in scope of delivery of VibroGo®)	

Tripods		
VIB-A-T0X Tripod	Rigid tripod for easy targeting on test objects. Available as standard version with manual 3-way fluid head, as geared pan/tilt head allows quick coarse adjustment and fine adjustment in 3 axes, or lightweight version of ~1.6 kg (recommended max. load 4 kg).	

Transportation case		
VIB-A-CAS16 Transp. case (VibroGo® VGO-200)	Robust transportation case for VibroGo®. Included with sensor. Provides space for VibroGo®, the plug-in power supply and also for optional accessories like mobile power supply and WLAN stick.	

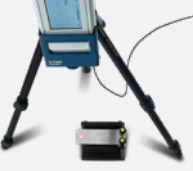
Education Kit		
VibroGo® Education Kit in transportation case	Practical experiments incl. material and script for the introduction to optical vibration measurement technology with the VibroGo® (e.g. vibration analysis with cantilever beams, loudspeaker characterization), with analog data acquisition (VIB-E-220) and VibSoft software, DeskSoft-PRM data analysis software Premium, various connection cables, packed in a robust transportation case.	

Compliance with standards		
Laser safety	IEC/EN 60825-1	
Electrical safety	IEC/EN 61010-1	
EMC	Emission:	Limit class B IEC/EN 61000-3-2 and 61000-3-3
	Immunity:	IEC/EN 61000-4-2 to 61000-4-6 and IEC/EN 61000-4-11
RoHS	IEC/EN 63000	

Polytec offers a wide range of accessories for setting up and performing measurements. Please contact your local vibrometer sales engineer or visit our website www.polytec.com/vibrogo for more detailed information.

All dimensions in mm if not marked otherwise

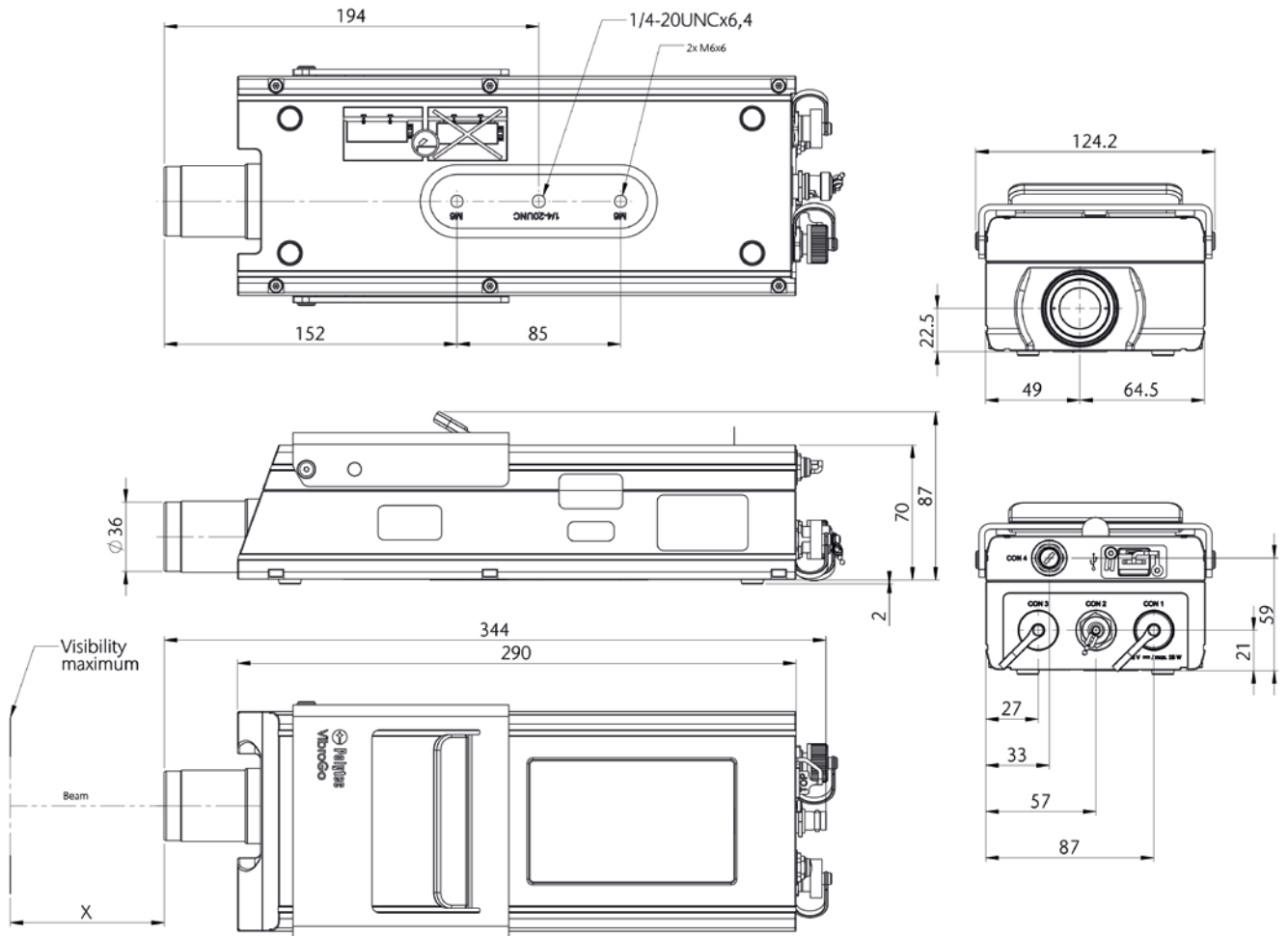

Shaping the future since 1967

High tech for research and industry.
Pioneers. Innovators. Perfectionists.

Find your Polytec representative:
www.polytec.com/contact

Polytec GmbH · Germany
Polytec-Platz 1-7 · 76337 Waldbronn