

ProSpeed® LSV-2100

Precise speed and length measurements are critical for controlling the production of continuous materials, sheet materials and piece goods. ProSpeed® – the next generation LSV Laser Surface Velocimeters – optimize production processes by providing reliable measurements and increase the output worldwide in the metals, cable and converting industries.

Due to the highly precise, non-contact measurement principle, ProSpeed® laser sensors eliminate common problems of traditional contact-wheel measurement methods such as damage to delicate surfaces, slippage and thermal expansion on almost any surface.

The enhanced connectivity of the ProSpeed® LSV-2100 ensures transparency – anywhere and anytime. The optical sensor determines the direction of motion and standstill conditions, with extended stand-off distances of up to 3 m, adding flexibility for measurements under harsh conditions. For additional protection, choose the thermo-protective housing (TPH).



Highlights

- Easy process integration with long stand-off distances up to 3 m
- Transparency thanks to the enhanced connectivity (web interface, Ethernet, field bus protocols)
- Multi user access (3 via Ethernet + 1 serial)
- Gauge permanently adjusted*
- Determines direction of motion and standstill
- Visible laser for easy alignment
- Robust sensor technology (IP 66, 67)

* The extremely stable optics concept of the LSV does not require re-adjustment due to technical reasons. Local laws and quality control regulations may require recalibrations.

ProSpeed® LSV-2100

Precise, non-contact speed and length measurement

Datasheet



Technical data



Metrological specifications

Nominal working distance [mm]	300	500	700	1000	1500	2000	2500	3000
Depth-of-field [mm]	120	120	140	140	140	200	200	200
Minimal velocity [m/min]	0 (standstill)							
Maximal velocity [m/min]	±7700			±10,000			±12,300	±14,600
Max. Acceleration [m/s ²]	400	400	400	400	400	530	660	800
Measurement units	m/min, ft/min, m or ft (selectable)							
Accuracy	<0.05 % of reading*							
Repeatability	<0.02 % of reading*							
Measurement value output rate	1024 s ⁻¹							
Standard interfaces	<ul style="list-style-type: none"> ■ RS-422 ■ Multi User Ethernet (10/100 Mbit/s) ■ Web Interface 		<ul style="list-style-type: none"> ■ Encoder (user-selectable, max. 500 kHz) ■ 24 V Status-I/O 					
Optional interfaces	<ul style="list-style-type: none"> ■ Profibus-DP ■ Profinet-IO ■ Ethernet / IP** 		<ul style="list-style-type: none"> ■ Analog (voltage/current optional) ■ Wireless Ethernet 					

* Under controlled conditions

** In preparation

Optical specifications

Wavelength	650 - 700 nm (visible laser beam)
Laser power	max. 25 mW
Laser class	3B
Beam cross section	2 x 4 mm

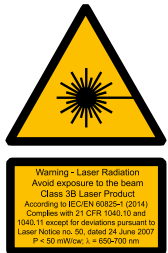

General specifications

	ProSpeed® LSV-2100	incl. thermo-protective housing TPH
Dimensions (L x W x H)	300 x 120 x 110 mm	727 x 256 x 254 mm
Weight	4.3 kg	36 kg
Power consumption	24 V DC / max. 20 W	
Operation temperature	0 ... +45 °C	-20 ... +200°C
Relative humidity	non-condensing	

Compliant with standards

Protection class	IP66 and IP67 (according to EN 60529) IP66, IP68 and IP69K with Thermo-Protective Housing
Mechanical shock reliability	10g according to EN 60068-2-29 (IEC 68-2-29)***
Vibration reliability	according to EN 60068-2-6 (IEC 68-2-6)***

*** The mechanical shock and vibration reliability of the optical sensor ProSpeed® LSV-2100 has been verified by a third party test institute.



ProSpeed® LSV-2100 in the rugged thermo-protective housing TPH

In hot and harsh environments the ProSpeed® LSV-2100 sensor receives additional protection by the special thermo-protective housing (TPH). This robust cast aluminum housing with integrated stainless steel cooling coils expands the operation temperature range up to -20 ... 200°C. The coolant can either be water, rolling coolant, paraffin oil or kerosene. An optional heat shield protects the system from heat radiation.

Accessories



Connection box

The connection box is completely wired for instant operation and contains a full terminal block, a universal power supply and a LAN connector.



Touch display*

The 7" touch display simplifies parametrization and visualization of measurement values on site. It uses the same intuitive user interface, as known from operating the measurement system via laptops, smartphones and tablet PC. This way users feel at home, no matter the device they use to operate the ProSpeed® LSV-2100.

* In preparation



Air wipe with exchangeable window

This front-mounted, aerodynamically optimized air wipe unit keeps the exchangeable window free of dust and steam. For cleaning or replacement, the window can easily be exchanged.



Mounting platform

The 3-axis adjustable mounting platform simplifies the precise alignment of the LSV sensor in relation to the measurement object. When mounting the LSV in a cooling housing, a suitable mounting platform is available.



Cooling plate

The cooling plate assures the sensor to stay in its operational temperature range, even under hot ambient conditions of up to +74°C.

Further accessories

Measurement frame installation kit, air amplifier, 87°/90° beam deflection unit, beam protective sleeve, cable protection, air preparation unit

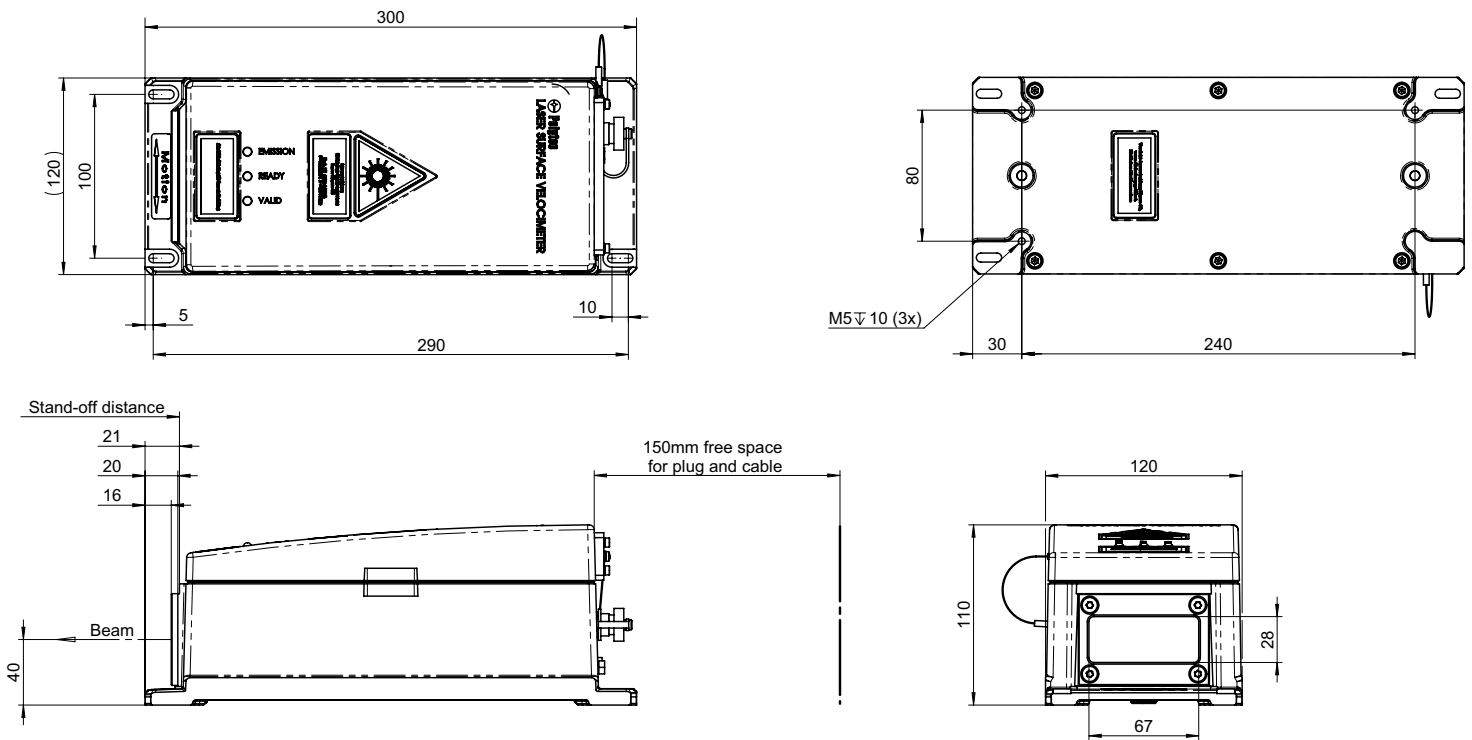

More Information

For more information please contact your Polytec application/sales engineer or visit the LSV homepage www.velocimeter.us and www.velocimeter.co.uk.

Shaping the future since 1967

High tech for research and industry.
Pioneers. Innovators. Perfectionists.

Find your Polytec representative:
www.polytec.com/contact

Polytec GmbH · Germany
Polytec-Platz 1-7 · 76337 Waldbronn